

Outdoor Bollard Fitting

INSTRUCTION MANUAL

Safety Warnings

- It is recommended that this light be installed by a qualified electrician in accordance with current IEE Wiring Regulations and Building Regulations (Part P).
- This product is only suitable for connection to a 240v~50Hz supply and is for outdoor use.
- This fitting is a Class I product, and **must** be connected to Earth.
- Switch off the mains supply and remove the appropriate fuse or switch off the appropriate circuit breaker before commencing installation.
- Run supply wire from a 5-amp electrical supply using double insulated 2 or 3-core cable of type H05RN-F 1.0mm² (not supplied) to selected site, ensuring it is adequately protected through the full length of the cable run, it must come out of the flat surface of the wall in line with the entry to the fitting
- Except where installed in a conduit or duct which provides equivalent protection against mechanical damage, a cable buried in the ground shall incorporate an earthed armour or metal sheath or both, suitable for use as a protective conductor, or be of insulated concentric construction. Buried cables shall be marked by cable covers or a suitable marking tape. Buried conduits and ducts shall be suitably identified. Buried cables, conduits and ducts shall be at a sufficient depth to avoid being damaged by any reasonably foreseeable disturbance of the ground.
- This product is protected against the ingress of moisture (IP44). If the glass or diffuser is broken or cracked it must

be replaced, please consult your retailer. This is the symbol which denotes this requirement:

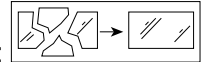

- This product must only be installed to a solid, fixed surface, such as concrete, decking or paving slabs. It must **NOT** be installed on soil.
- This product contains non-replaceable LEDs. If the LEDs become damaged, they cannot be replaced, and the product must be scrapped.
- If any modification is made it will invalidate the warranty and may render the product unsafe.
- Allow 10 minutes to cool before replacing, adjusting or cleaning. To achieve maximum corrosion resistance the surface of the Stainless Steel must be kept clean. Surface contamination and the formation of deposits, such as salt crystals, are critical factors which may lead to drastically reduced life. Careful washing with soap or a mild detergent and warm water followed by a clean water rinse and finally wiping dry is usually adequate for most S/S items used in the domestic environment. Care must be taken to turn off the mains supply until the cleaning process has been completed and the fitting is completely dry.

Assembly/ User Instructions

Before you start

Please read these instructions carefully before fitting and retain for reference. Check the packaging, making sure you have all required parts. Follow each assembly step to prevent incorrect assembly. Ensure the product is fully assembled as illustrated before use. Ensure there are no cables/ pipes beneath the surface (other than the supply cable for this fitting). The mounting surface must be solid, fixed and able to accommodate the weight/ height of the fitting. If installing on an existing secure base, use the holes in the post base as a template to drill suitable fixing holes and prepare with suitable ground fixing bolts (not supplied). The supply cable (at least 250mm) must come from the mounting surface, directly into the terminal block of the fitting.

DO NOT CONNECT THIS PRODUCT TO A DIMMER SWITCH.

The Light pack contains:

Light fitting.
Terminal connection block(s).
Fixing pack.

The following tools may be required:

Selection of cross and flat head screwdrivers.
Electric drill and assorted drill bits.
Wire strippers.
Electrical insulation tape.

These assembly diagrams are intended as a guide – if in doubt consult a qualified electrician.

Assembly/ User Instructions Continued

1. **Diagram A.** Determine the position of your light fitting. Ensure there is sufficient power cable to connect to the fitting – we recommend at least 250mm. Take a note of the position of the electrical connections. Ensure there is a solid mounting surface - do not install on soil.
2. Place the base of the light fitting over the cable and use it as a template to mark the mounting hole positions. Drill and plug the holes ready to mount the fitting later.
3. **Diagram B.** Pull the terminal block assembly out of the base of the fitting. Remove the cable clamp and take the lid off the terminal block housing to expose the internal terminal block.
4. Connect the house wiring to the terminal block - see expanded wiring diagram. When you are sure of the connections wrap the Terminal Block and overlap the wiring both sides with 2 layers of insulation tape. **NOTE: This is a Class I fitting and must be earthed.** Any loose terminal blocks - not secured to ceiling cup - should always be covered with 2 layers of good quality insulation tape. Re-fit the back box ensuring no wires are damaged, trapped or left exposed. Check the seal, use sealant if required.
5. Secure the cable clamp over the incoming cable and then push the terminal block assembly fully inside the base.
6. Secure the post to the mounting surface making sure that all cables are contained inside the fitting.
7. Turn on the power and test.

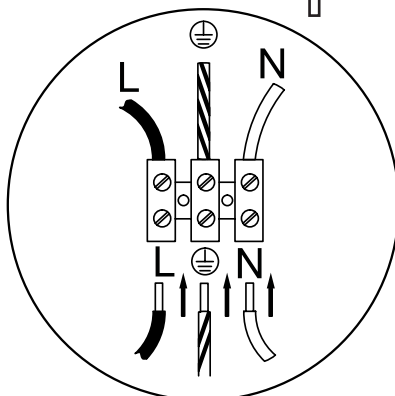
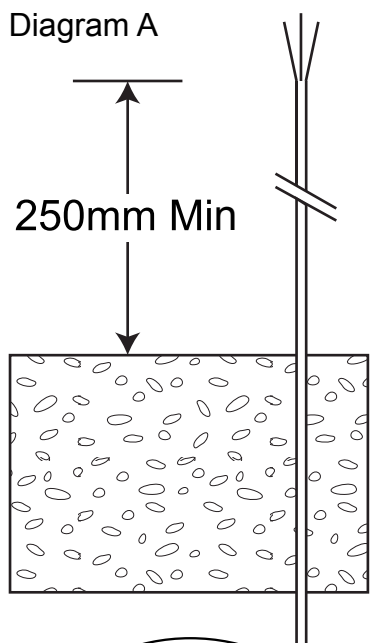

Expanded Wiring Diagram

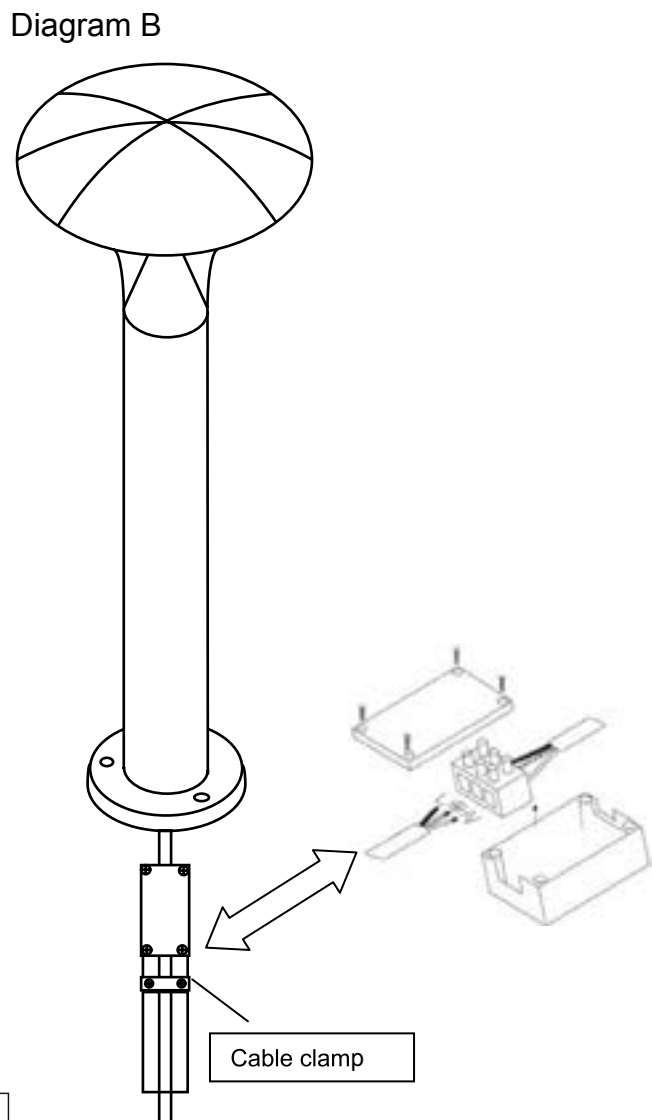

- EN Scan QR code for multi-language
- FR Scannez le code QR pour plusieurs langues
- ES Escanee el código QR para varios idiomas
- PL Zeskanuj kod QR dla wielu języków
- DE Scannen Sie den QR-Code nach mehreren Sprachen
- IT Scansiona il codice QR per multilingua