

# Flush Light Fitting

## INSTRUCTION MANUAL

### Safety Warnings

- This product is only suitable for connection to a 240V~50Hz supply in accordance with current IEE wiring regulations. It should be installed in accordance with local building regulations and is for domestic ceiling use only. It is not suitable for a bathroom location.
- Before installing your light fitting always switch off the mains supply and remove the appropriate fuse or switch off the appropriate circuit breaker before commencing installation.
- This is a Class I product and **must** be connected to Earth. The terminal blocks are supplied according to requirements of the fitting.
- Never fit bulbs of a higher wattage than those specified on the label, as these may cause overheating and damage the fitting.
- This product contains delicate parts – be careful during handling and maintenance to avoid breakage.
- If you are in any doubt about your competence please consult a qualified electrician.
- If any modification is made it will invalidate the warranty and may render the product unsafe.

### Care Information

Allow 10 minutes to cool before replacing, adjusting or cleaning.

Clean with a dry cloth only. Do not use liquid or abrasive cleaners on this product.

### Assembly/ User Instructions

#### Before you start

Please read these instructions carefully before fitting and retain for reference. Check the packaging and make sure that you have all the required parts. Follow each assembly step in order to prevent incorrect assembly. Ensure that the product is fully assembled as illustrated before use.

#### The Light pack contains:

Light fitting.

Terminal connection block(s).

Fixing pack.

#### The following tools may be required:

Selection of cross and flat head screwdrivers.

Electric drill and assorted drill bits.

Wire strippers.

Electrical insulation tape.

**These assembly diagrams are intended as a guide – if in doubt consult a qualified electrician.**

1. Decide on the position of the light fitting, or remove existing light fitting. Note the position of the electrical connections. Ensure there is a solid mounting surface, preferably a wooden joist or joist bridge to support the weight of the light fitting.
2. If the fitting is pre-assembled, unscrew decorative finial (5) and remove glass (6).
3. Use the fixing plate as a template to mark the screw holes. Make the screw holes, supporting your fitting and connect the house wiring to the terminal block (2) – see expanded wiring details below. **NOTE: This is a Class I fitting and must be earthed.** The 4th terminal block connector is used for the “loop” wires of the “Ring Circuit”. There may be more than one set of cables in the “loop” connections. If there is a “Ring Circuit” and you do not understand the connections you must consult an electrician. Any loose terminal blocks – not secured to ceiling cup – should always be covered with 2 layers of good quality insulation tape.
4. Secure the fixing plate to the ceiling using the appropriate fixings (1 & 3).
5. Fit the bulbs, being careful not to touch it with your bare hands - use a cloth or gloves. **NOTE: Never fit bulbs of a higher wattage than those specified on the label (as these may cause overheating and damage the fitting).**

## Assembly/ User Instructions Continued

6. Screw the centre threaded tube (4) into place, and tighten the locking nut, ensuring the rubber washer is fitted to protect the glass.
7. Slot the glass shade (5) over the centre threaded post and secure with the decorative finial (6).
8. Turn on the power and test.

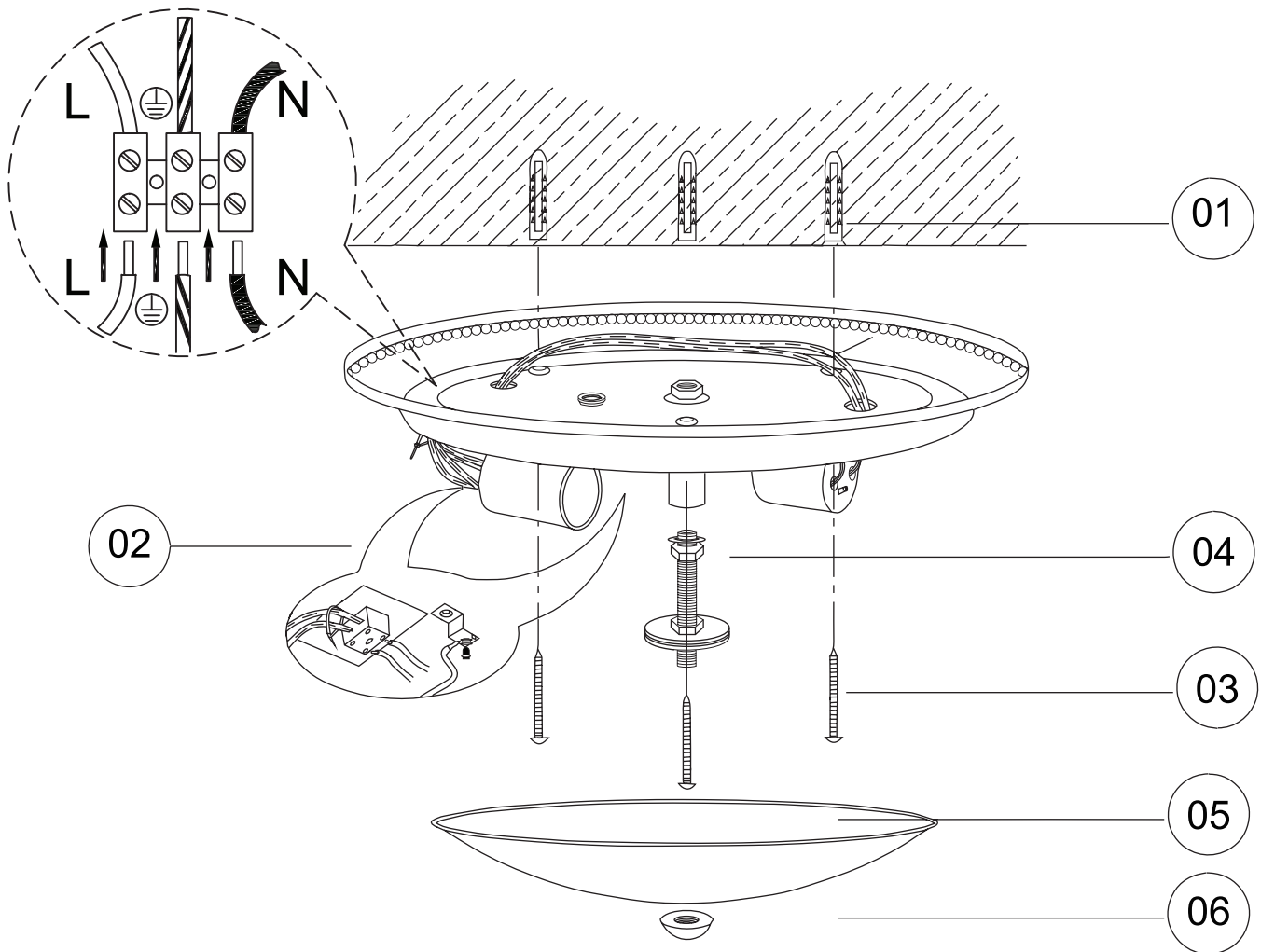

- EN Scan QR code for multi-language
- FR Scannez le code QR pour plusieurs langues
- ES Escanee el código QR para varios idiomas
- PL Zeskanuj kod QR dla wielu języków
- DE Scannen Sie den QR-Code nach mehreren Sprachen
- IT Scansiona il codice QR per multilingua



UK Manufacturer: BH17 7BY  
EU Manufacturer: Brilliant AG,  
Brilliantstrasse 1, D-27442 Gnarrenburg