

## Commissioning

- Replace the cover on the terminal block. Wrap the earth and loop connection in two layers of insulation tape, and push these into the ceiling cavity.
- Lift the ceiling cover into place and screw into position.
- Tighten the screws to secure. Take care not to trap any wiring.
- Attach crystals by locating the split pin through the slot and pushing up until the diamond has gone into the slot.
- Replace fuse or circuit breaker and switch on. Your light is now ready for use.

## Fitting/replacing bulbs

- When changing a bulb, always switch off at the mains and allow the bulb to cool before handling. Used bulbs should not be disposed of with household waste. Please recycle where facilities exist.
- Always use the correct type and wattage bulb. Using the incorrect wattage bulb will damage the product.
- Use a soft cloth to handle bulbs, avoid directly touching the bulbs as this will shorten their life.
- Unscrew the bulb cover. Pull the bulb out to remove.
- Push the new bulb in. Refit the bulb cover.

We recommend cleaning with a soft dry cloth. Do not use solvents or abrasive cleaners as these could damage the finish.

Glass parts – Remove and wash in warm water or just use a damp cloth. Do not use abrasive materials as these will damage the finish.

## Recycling advice



Waste electrical products should not be disposed of with household waste. Please recycle where facilities exist. Check with your Local Authority or retailer for recycling advice.

## Safety information

For your safety, always switch off the supply before changing lightbulbs, or cleaning.

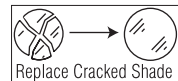

This bulb is protected by a glass shade. This part must be replaced immediately should the glass shade become cracked or damaged. This fitting must not be used without the glass shade in place.



- EN Scan QR code for multi-language
- FR Scannez le code QR pour plusieurs langues
- ES Escanee el código QR para varios idiomas
- PL Zeskanuj kod QR dla wielu języków
- DE Scannen Sie den QR-Code nach mehreren Sprachen
- IT Scansiona il codice QR per multilingua

## Instruction leaflet

# Flush Light

91811



Thank you for purchasing this light fitting. Please read the instructions carefully before use to ensure safe and satisfactory operation of this product. Please retain these instructions for future reference.

## Warning

**This light fitting is double insulated (class 2) and does not require connection to an Earth circuit**

Please read these instructions carefully before commencing any work.

This unit must be fitted by a competent and qualified electrician.

Install in accordance with IEE Wiring regulations and current Building Regulations.

To prevent electrocution switch off at mains supply before installing or maintaining this fitting. Ensure other persons cannot restore the electrical supply without your knowledge.

This light fitting should be connected to a fused circuit.

If replacing an existing fitting, make a careful note of the connections.

Always use the correct type and wattage bulb. Never exceed the wattage stated.

When changing a bulb, always switch off at the mains and allow the old bulb to cool down before handling. Dispose of used bulbs carefully and responsibly. This product is suitable for dimming when used in conjunction with a dimmable lamp. Please ensure verification of dimming abilities with the lamp manufacture prior to use.

Waste electrical products should not be disposed of with household waste. Please recycle where facilities exist. Check with your local authority or retailer for recycling advice.

## Specification

Voltage: 220-240V~ 50Hz  
Lamp: 5 x Max. 3W LED G9  
IP rating: 44

## Layout

- Plan the desired layout of this fitting carefully, ensuring the cables will reach the distance between the junction box and the light fitting
- Avoid locating any cables in positions that would cause a hazard. Position cables and junction boxes (not supplied) away from areas where they may be at risk from being cut, trapped or damaged
- The mains supply cable must have a minimum cross sectional area of 1.0mm<sup>2</sup>
- This product must be mounted out of arms reach.
- This product has special protection against the ingress of moisture and is IP44 rated.

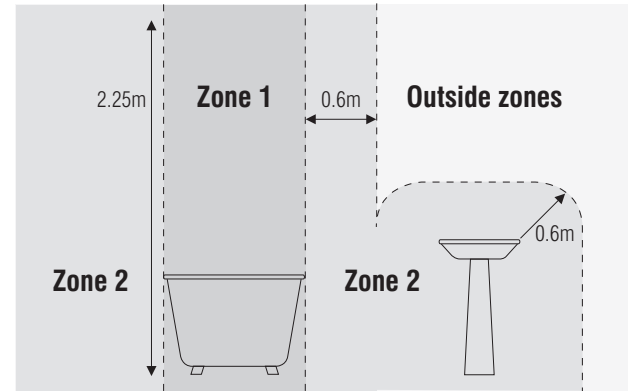

This product is suitable for use in Zone 2 and outside Zones of a bathroom. See diagram. If this unit is being fitted in a room containing a bath or shower, a 30mA RCD must be used, in accordance with IEE regulations.

## Installation

Existing fittings must be completely removed before installation of a new product. Before removing the existing fitting, **carefully note the position of each set of wires.**

- Undo the four screws holding the ceiling bracket in place and set aside
- Hold the ceiling bracket in place and mark the position of the holes.

- Ensure the ceiling is capable of holding the weight of the product. Take care to avoid damaging any concealed wiring and pipes. The correct fixings should be used. Ensure there is a joist at the point of fixing to support the weight of the product.
- Fix the ceiling bracket into position.

## Wiring

Having correctly identified the wiring from your existing light fitting, pull the wire through the hole and connect to the connection block on the product in the following way: This unit is double insulated and must not be earthed.

SUPPLY

LIGHT FITTING

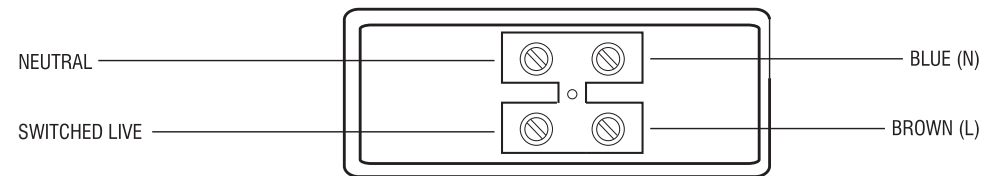

## Check that...

- You have correctly identified the wires
- The connections are tight
- No loose strands have been left out of the connection block.