

# Flush Light Fitting

## INSTRUCTION MANUAL

### Safety Warnings

- These products are only suitable for connection to a 220-240V~ 50Hz supply in accordance with current IEE Wiring Regulations and should be installed in accordance with local Building Regulations. They are for Domestic ceiling use only, and are not suitable for a Bathroom location.
- Before installing your light fitting always switch off the mains supply and remove the appropriate fuse or switch off the appropriate circuit breaker before commencing installation.
- This is a Class II, Double Insulated product  This Fitting does not require an Earth, and Live or Neutral **must not** be connected to Earth. The terminal blocks are supplied according to requirements of the fitting.
- This fitting contains non-replaceable LEDs. If the LEDs become damaged, the fitting must be scrapped.
- If you are in any doubt about your competence please consult a qualified electrician.
- This product contains delicate parts – be careful during handling and maintenance to avoid breakage.
- This fitting is heavy/ awkward and you may require assistance during installation. When fixing to the mounting surface ensure that the fixings used are appropriate.
- If any modification is made it will invalidate the warranty and may render the product unsafe.

### Care Information

Allow 10 minutes to cool before replacing, adjusting or cleaning.

Clean with a dry cloth only. Do not use liquid or abrasive cleaners on this product.

### Assembly/ User Instructions

#### Before you start

Please read these instructions carefully before fitting and retain for reference. Check the packaging and make sure that you have all the required parts. Follow each assembly step in order to prevent incorrect assembly. Ensure that the product is fully assembled as illustrated before use.

#### The Light pack contains:

Light fitting.

Terminal connection block(s).

Fixing pack.

Decorative Balls as illustrated below:

#### The following tools may be required:

Selection of cross and flat head screwdrivers.

Electric drill and assorted drill bits.

Wire strippers.

Electrical insulation tape.

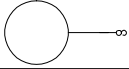
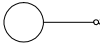
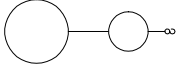
NO	PARTS LIST	Qty	NO	PARTS LIST	Qty
A		6	C		3
B		3	D		1

**These assembly diagrams are intended as a guide – if in doubt consult a qualified electrician.**

1. Decide on the position of the light fitting / or remove existing light fitting. Take a note of the position of the electrical connections. Ensure there is a solid mounting surface, preferably a wooden joist or joist bridge to support the weight of the light fitting.
2. Remove the two side screws (4) and retain them for re-use. Use the fixing bracket (1) as a template to mark the screw holes, and secure to the ceiling with appropriate fixings (2).
3. Support your fitting and connect the house wiring to the terminal block (3) – see expanded wiring details below. **NOTE: This is a Class II fitting and must NOT be earthed.** Any loose terminal blocks – not secured to ceiling cup – should always be covered with 2 layers of good quality insulation tape.

## Assembly/ User Instructions Continued

4. Secure the ceiling cup over the bracket by using the screws (4) removed in Point 2.
5. Carefully hang the decorative balls onto the frame (5).
6. Turn on the power and test.

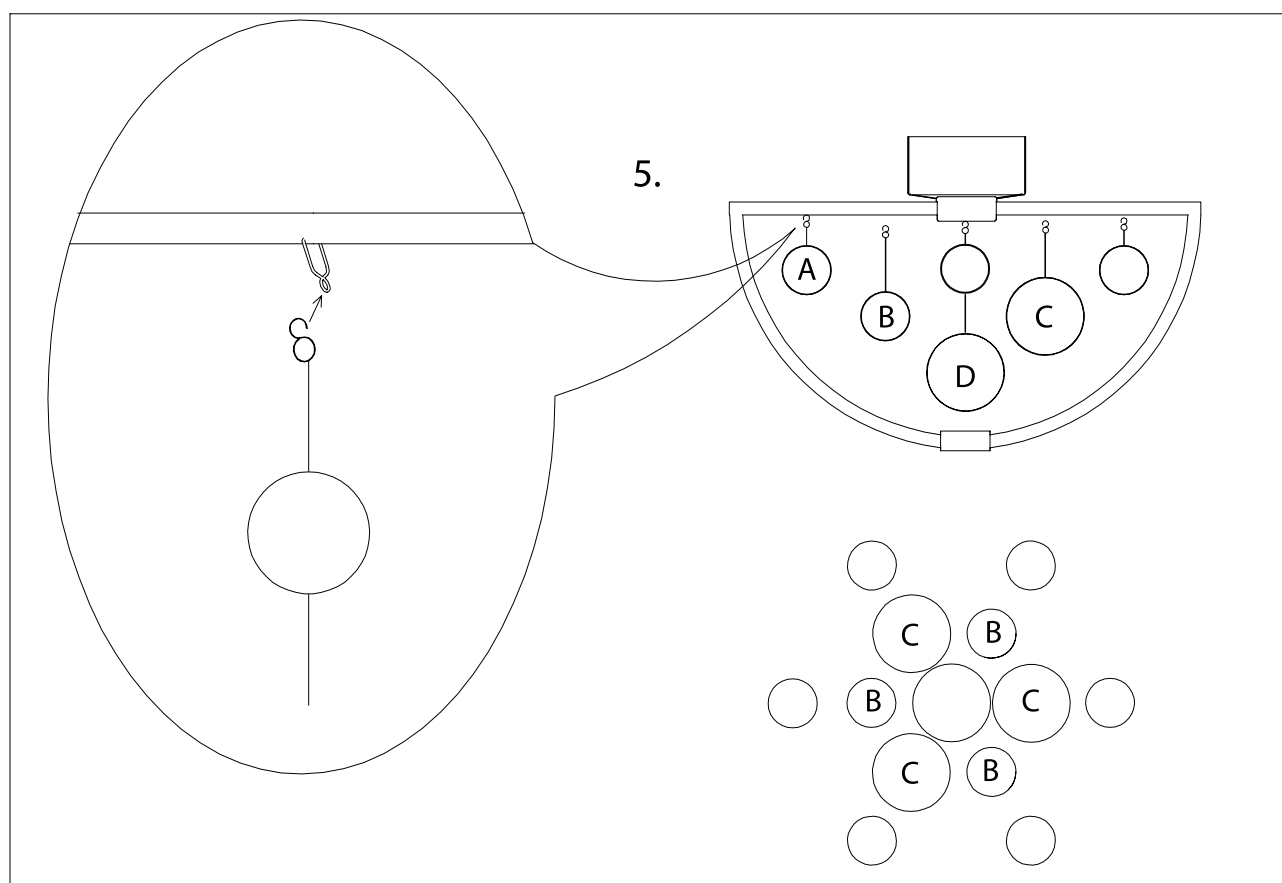
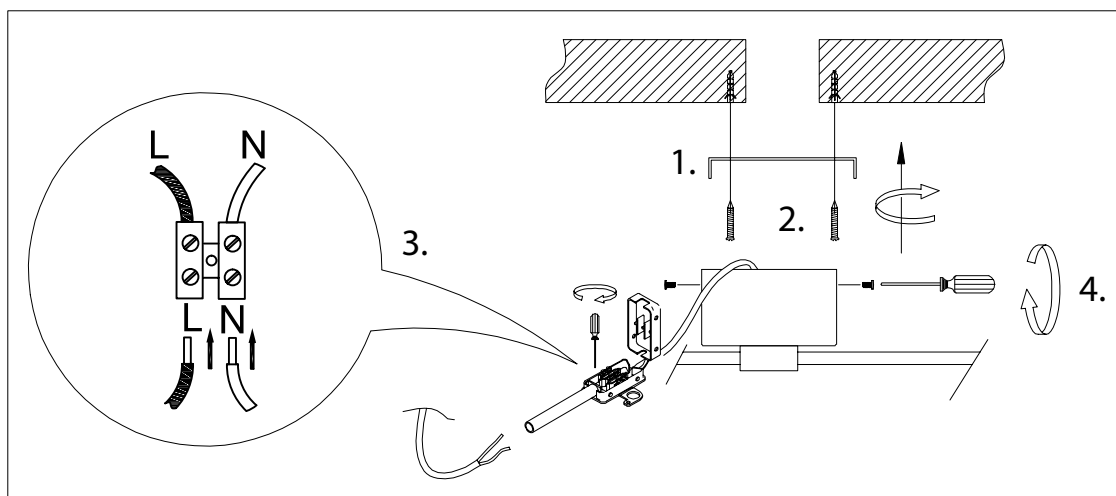

- EN Scan QR code for multi-language
- FR Scannez le code QR pour plusieurs langues
- ES Escanee el código QR para varios idiomas
- PL Zeskanuj kod QR dla wielu języków
- DE Scannen Sie den QR-Code nach mehreren Sprachen
- IT Scansiona il codice QR per multilingua



UK  
CA  
CE  
UK Manufacturer: BH17 7BY  
EU Manufacturer: Brilliant AG,  
Brilliantstrasse 1, D-27442 Gnarrenburg